

72-F

1. DECREE -- Ivan Hughes, et al. -vs- Val Jones, et al. 72-0147 thru 72-0174

MICROFILMED

SCANNED
APR 04 2007

RECEIVED

JUL 30 1996

INTER-DEPARTMENT MEMO — 1

FROM Terry Blau

DATE 2-20-85

TO File #s 72-0163-72-0166

SCANNED
APR 04 2007

SUBJECT Source Error

Upon reviewing the H.E.S. Plats it was discovered that the source serving H.E.S. No. 614 should be Van Horn Creek rather than Alder Cr. and the source serving H.E.S. No. 263 should be Alder Cr. rather than Van Horn Cr.

RECEIVED

JUL 30 1996

RECEIVED
FEB 22 1985

Department of Water Resources

9000 0 & 700

P/4 72-163 & 72-164

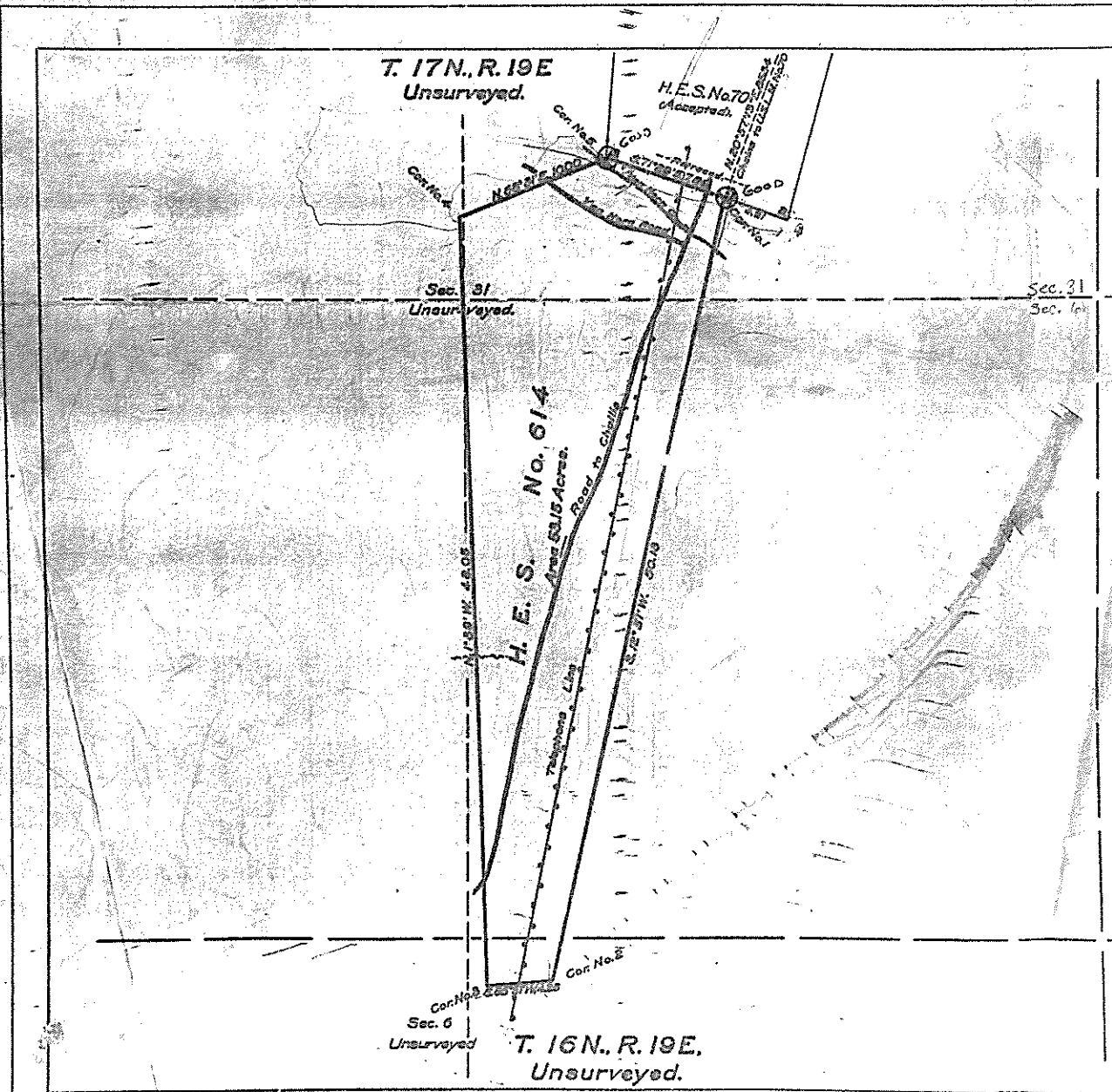

SCALE 5 chains to 1 inch

Subvs.	Int. Cont. Group	When Surveyed	Area in Acres

P/4 72-0158-72-0160

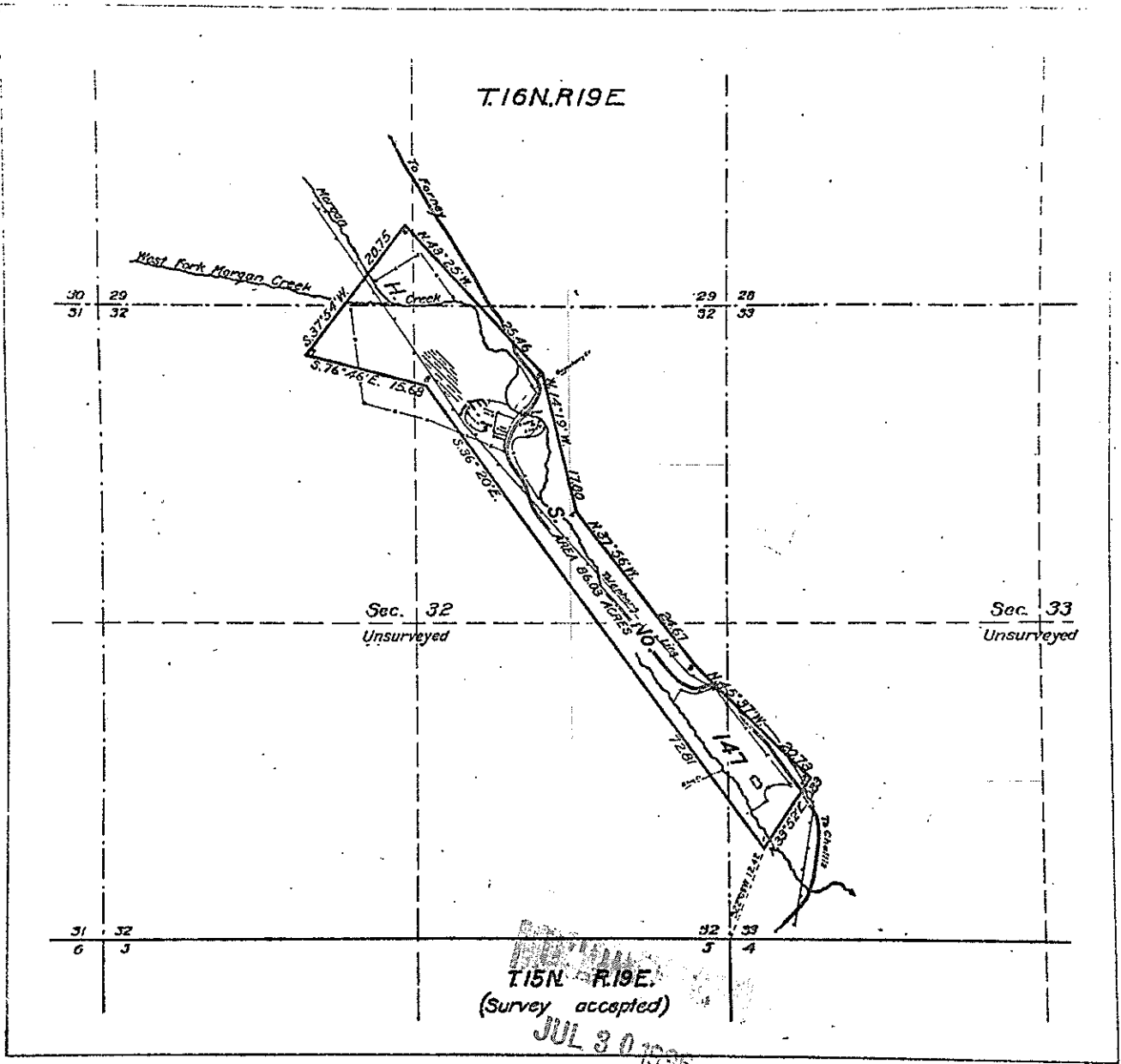

SCALE 10 chains to 1 inch.

Surveyors Designated	When Surveyed	Book, Page, Group		Where Surveyed			Date of Approval
		Book	Page	Area	Region	Completed	
M. B. No. 147, John C. Brown, Surveyor-Draftsman, Forest Service	1917	72	11	April 1, 1911	May 9, 1911	May 11, 1911	Nov 26, 1912

H. E. Survey No. 147		Areas in Acres	
		Conduits	
In Section			
In Section			
In Section			
In Section			
Total		86.03	

P/ce 72-0155-0157

Form 165A

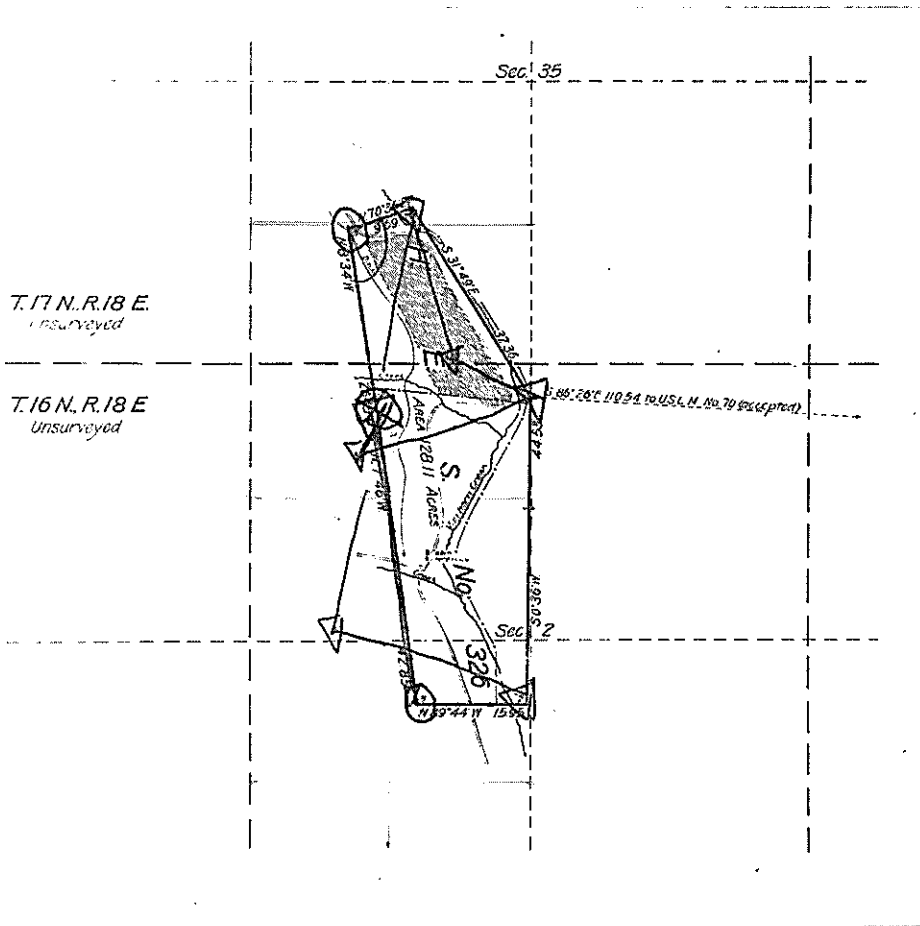
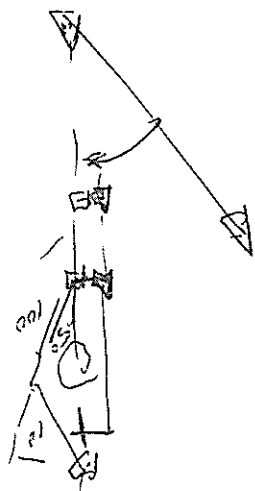

Plot of
**HOMESTEAD
 ENTRY SURVEY**
 No. 326
 in the
**CHALLIS
 NATIONAL FOREST**
 in
 Sec. 35 unsurveyed, T. 17 N., R. 18 E.
 Sec. 2 unsurveyed T. 16 N. R. 18 E.
 of the
**BOISE BASE AND MERIDIAN
 IDAHO**

This plot of Homestead Entry Survey No. 326 State of Idaho is strictly conformable to the field notes thereof on file in this office, which have been examined and approved.

U.S. Surveyor General's Office
 Boise Idaho
 October 3, 1914

Edmund H. Adair
 U.S. Surveyor General

SCALE 10 chains to 1 inch

Survey Designated	By whom Surveyed	That Part No.	Date	When Surveyed		Date of Approval
				Began	Completed	
326	W. E. Adams	326	Mar 10 1915	July 2 1915	Aug 4 1915	

Areas in Arise	
H. S. Survey No. 326	Conflicts
In Section	
By Section	
In Section	
By Section	
Total	120 11

Act of June 11, 1908	Act of March 4, 1909
File No. 42523	Serial 223251
Latitude 44° 47' 53.7"	
Longitude 116° 13' 30.11"	
Mean Day Day 222-33.6	
At Course No. 1	

JUL 30 1916

RECORDED

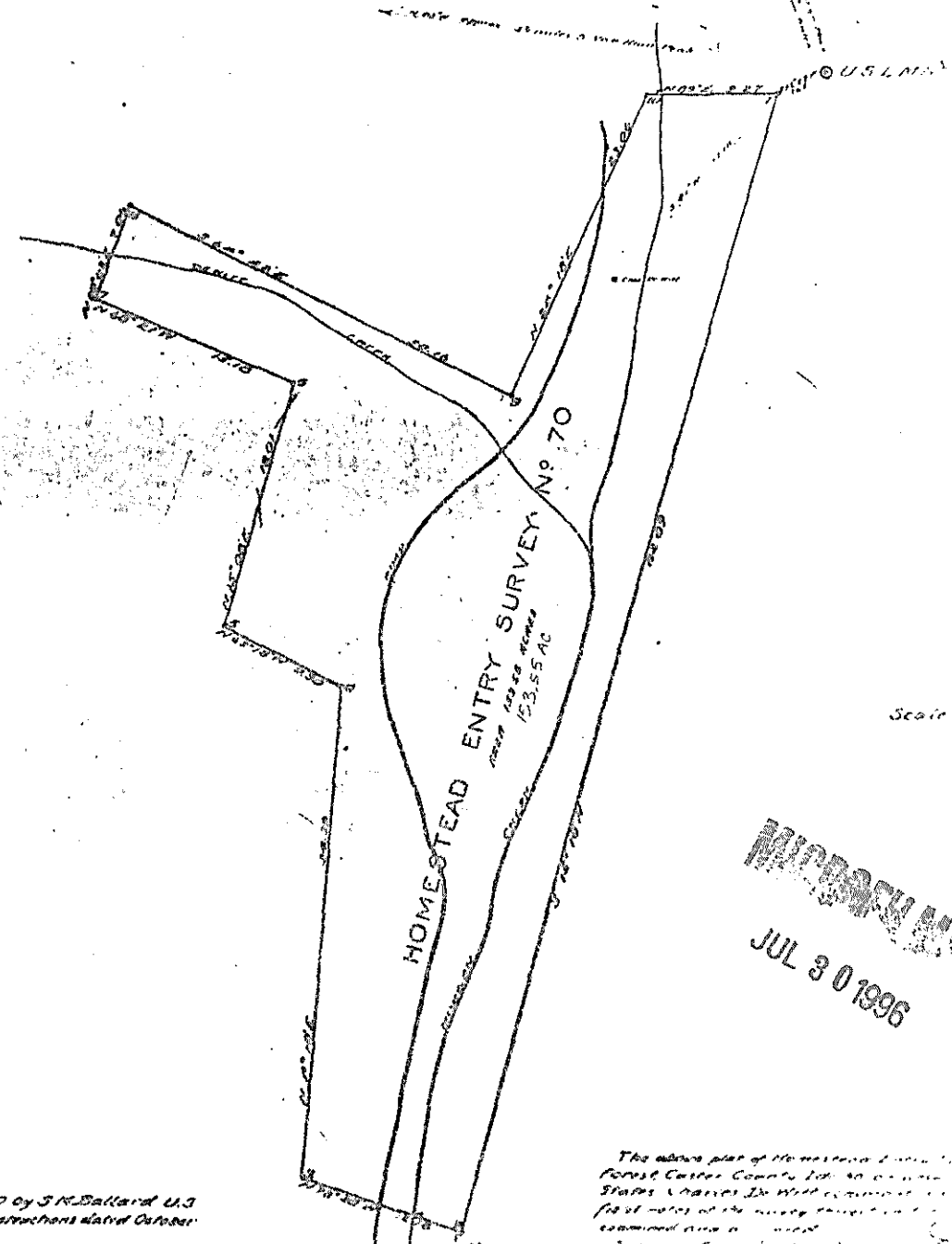
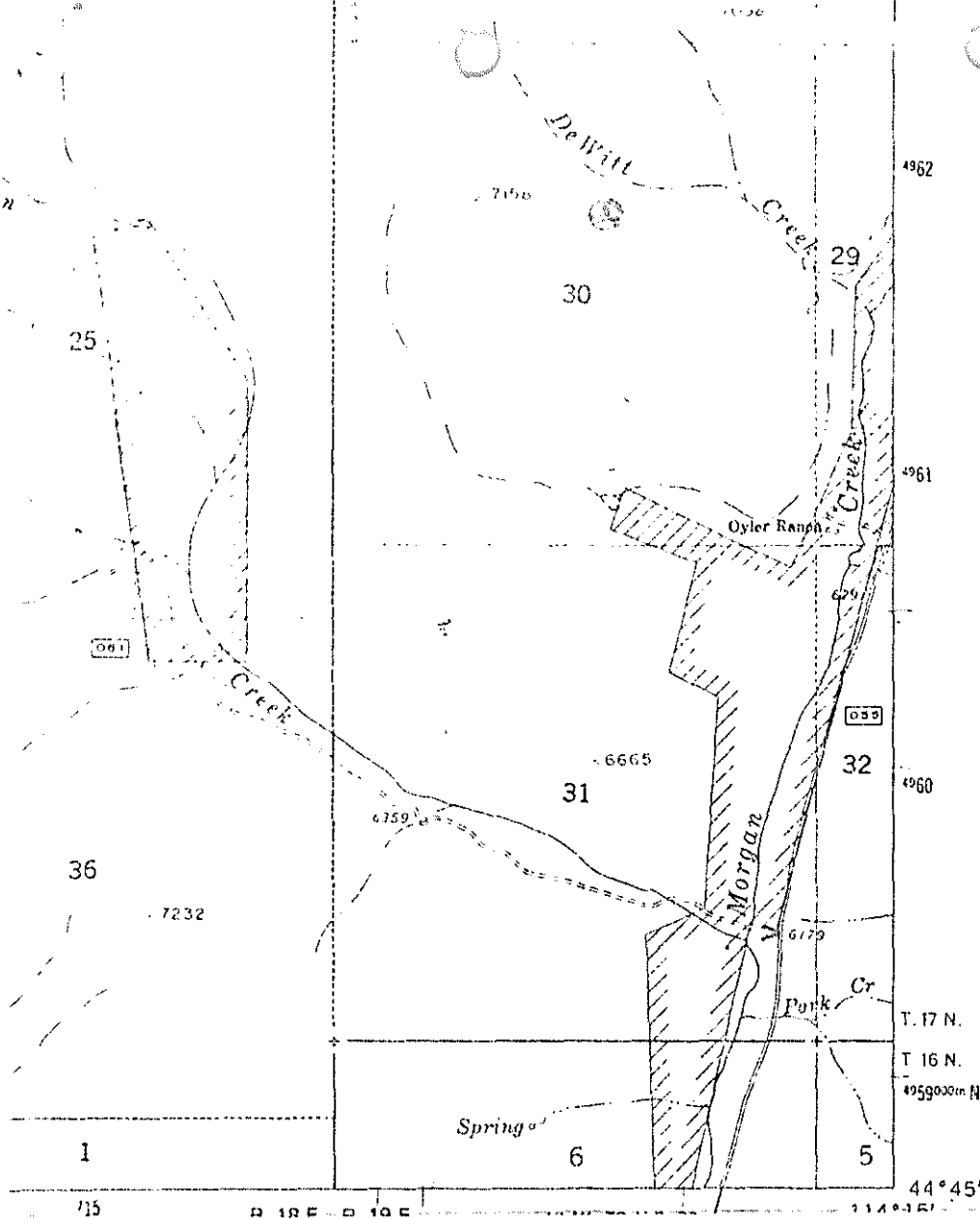

revised November 12, 1910 by S. R. Ballard, U.S. Surveyor under Special Instructions dated October 10, 1910
 magnetic declination 13° E

The above plat of Homestead Entry No. 70, in Forest, Carter County, Idaho, is in compliance with the provisions of the Act of March 3, 1909, Chapter 126, 35 Stat. 845, and the Act of August 10, 1909, Chapter 126, 35 Stat. 845, and the Act of August 10, 1909, Chapter 126, 35 Stat. 845, and the Act of August 10, 1909, Chapter 126, 35 Stat. 845.

RECORDED
 JUL 30 1996

P/U 72-0171 - P/U 720174

IN THE DISTRICT COURT OF THE SIXTH JUDICIAL DISTRICT OF THE
STATE OF IDAHO, IN AND FOR THE COUNTY OF
CUSTER.

72-7

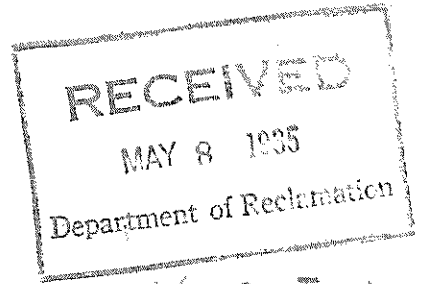

IVAN HUGHES, JULIUS BLUME)
AND IVAN BLUME,)

Plaintiffs,)

-vs-

D E C R E E

VAL JONES, VERL JONES, VERA)
JONES, VELMA JONES, and IDA)
PAY HESSEN, Minors, by NOVA)
HESSEN, their General Guardian;)
EARL MILLICK, INEZ W. THOMAS,)
MIKE HOGAN, PHILIP D. BEAVERS,)
PAUL HACKER and JOHN BOYD,)
Administrator of the Estate of)
GEORGE M. TURNER, Deceased,)

Defendants.)

File 3-I-1

This cause came on regularly for trial before the honorable Guy Stevens, Judge of said Court, sitting without a jury on the 1st day of May, 1935, at Challis, Custer County, State of Idaho, and the Plaintiffs and Defendants appearing by their respective attorneys, and the default of the non-answering defendants having been duly entered according to law, and the parties hereto having stipulated in open Court that the pleadings herein be deemed amended to conform to the Stipulation to be filed herein and the parties then by Stipulation being duly filed with the Court, having agreed upon a Decree and the matter having been presented to the Court and the same having been fully considered by the Court and the Court being fully advised in the premises finds that the decree should be entered in accordance with the Stipulation on file herein.

WHEREFORE, it is Ordered, Adjudged, and Decreed, as follows:

I. That Morgan Creek is a stream lying solely within the boundaries of Custer County, State of Idaho.

II. That each and every of the tracts of land described in the Complaint, complaints in intervention, answers and cross-complaints and Stipulation in this action belonging to the several parties Plaintiff and Defendant herein are arid in character and will not successfully raise any agricultural crops without the application of water thereon for the irrigation thereof and that all of said lands are susceptible of irrigation from the said Morgan Creek.

III. That one inch of water per acre or its equivalent in cubic feet per second of time is necessary and ample for the proper irrigation of said land.

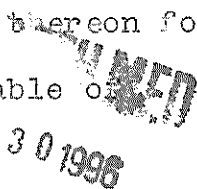

IV. That the dams and diverting works of the several parties to this action were at the time of the several appropriations and are now of sufficient size and capacity to carry and convey water so appropriated to and upon the several tracts of land of the said several parties for the irrigation thereof, and that each and every of the said several tracts of land are situated in Custer County, State of Idaho.

V. That each of the parties to this action plaintiffs and defendants hereinafter named, or their predecessors in interest were at the time of the several appropriations of water, made as hereinafter set forth, the owners respectively of the several tracts of land set forth and described in the complaints, answers, cross-complaints and Stipulation on file herein and that for the irrigation of the same the said parties, or their predecessors in interest, did respectively appropriate the quantities of water hereinafter stated, and on the dates and from the streams respectively hereinafter stated, and set opposite the names of each of said parties, such water being estimated under a four inch pressure, or its equivalent in cubic feet per second of time, and every since said dates of the said several appropriations said water has been so diverted and used on said lands in the irrigation thereof.

VI. That the following named persons parties to this suit are entitled to the uninterrupted use of the flow of the waters of Morgan Creek upon the lands mentioned and described in the Complaint, answers and cross-complaints and Stipulation on file herein and appurtenant to said lands as hereinafter specified in the following amounts and from the following dates, to-wit:

Ivan Hughes, is the owner of the east half of the northwest quarter and the northeast quarter of the southwest quarter, and Lots 2 and 3 of Section 24, Township 15, North Range 19 East, Boise Meridian. That he is entitled to 80 miners inches of water or 1.6 cu. ft. per second of the water of Morgan Creek with date of priority May 1st, 1878 and 20 miners inches or .4 second feet from September 14th, 1931, with the point of diversion from Morgan Creek at a point that is north 62 degrees, 30 minutes west, 2,480 feet from the west quarter corner of Section 24, Township 15, North Range 19 East, Boise Meridian. It being understood that any springs arising below the point of diversion are to be measured as the natural flow of the creek and included in and chargeable to the decree of Ivan Hughes.

Ivan Blume is the owner of the west half of the southwest quarter of Section 24 and the Northwest quarter of the Northwest quarter of Section 25, Township 15, North Range 19 East, Boise Meridian. That he is entitled to 40 miners inches or .8 cu. ft. per second from May 1st, 1907, and 10 miners inches or .2 cu. ft. per second of the waters of Morgan Creek, from Sept. 14, 1931 with point of diversion at a point south 12 degrees west 800 ft. from the west quarter corner of Section 24, Township 15 North, Range 19 East Boise Meridian.

Julius Blume is the owner of lots 1, 2 and 3, Section 26 and the Northeast quarter of the Northeast quarter and the Northwest quarter of the Northeast quarter of Section 26 and the Southeast quarter of the Southeast quarter of Section 23, Township 15 North, Range 19 East, Boise Meridian. That he is entitled to 90 miners inches or 1.8 cu. ft. per second under date of priority of May 2nd, 1878, and 22½ miners inches or .45 cu. ft. per second with date of priority, September 14, 1931, all from waters of Morgan Creek, with the point of diversion at a point South 85 degrees West 1900 ft. from the west quarter corner of Section 24, Township 15 North, Range 19 East, Boise Meridian. It being understood that any springs arising below the point of diversion are to be measured as the natural flow of the creek and included in and chargeable to the decree of Julius Blume.

That the defendants, Val Jones, Verl Jones, Vera Jones, Velma Jones and Ida Fay Hessen, Minors represented in this action by their duly appointed General Guardian, Nova Hessen, are the owners in common of H. E. Survey No. 264, embracing a portion of Sec. 20, Twp. 17 N. R. 19 E. B. M.; Beginning at corner No. 1, from which U. S. Location Monument No. 70 bears S. 27 degrees 20' W. 40.47 chains distant; thence S. 88 degrees 19' E. 28.96 chains to Cor. No. 2; thence N. 2 degrees 22' W. 19.10 chains to Cor. No. 3; thence N. 31 deg. 6' E. 44.26 chains to Cor. No. 4; thence N. 4 degrees 44' E. 21.22 chains to Corn. No. 5; thence S. 85 degrees 16' W. 8.15 chains to Cor. No. 6; thence S. 20 deg. 27' W. 21.18 chains to Cor. No. 7; thence S. 37 degrees 43' W. 63 and 12 hundredths chains to corner No. 8; thence S. 43' W. 6.42 chains to corner No. 1, the place of beginning, containing 137.77 acres. That they are entitled to 58 miners inches or 1.16 cu. ft. per second of water from May 1st, 1910, and 14½ miners inches or .29 cu. ft. per second of water from Morgan Creek, from Sept. 14, 1931, with point of diversion in the Southeast quarter of Southeast quarter of unsurveyed Section 17, Township 17 North, Range 19, East, Boise Meridian, and the second point of diversion in the Northwest quarter of the Southeast quarter of unsurveyed Section 20, Township 17, North, Range 19, East, Boise Meridian.

And the said parties are the owners of, H. E. Survey No. 326; Beginning at Cor. No. 1, from which U. S. Location Monument No. 70 bears S. 86 degrees 26' E. 110.54 chains distant; thence, S. 36' W. 44.53 chains to Corner No. 2; thence N. 89 degrees 44' W. 15.95 chains to corner No. 3; thence N. 7 degrees 46 minutes W. 42.85 chains to corner No. 4; thence N. 8 degrees 34' W. 26.45 chains to corner No. 5; thence N. 70 degrees 36' E. 9.69 chains to corner No. 6; thence S. 31 degrees 49' E. 32.36 chains to corner No. 1, the place of beginning, containing one hundred twenty-eight and eleven hundredths acres, in Section 2 Twp. 16, North, Range 18, and Section 35, Twp. 17, North, Range 18, East Boise Meridian. That they are entitled to 46 miners inches, or .8 cu. ft. per second from May 1st, 1914, and 12½ miners inches or .25 cu. ft. per second from May 1st, 1920, and 13 miners inches or .26 cu. ft. per second from waters of Morgan Creek, from September 14, 1931, with point of diversion at a point Southwest quarter of Southwest quarter of unsurveyed Section 35 in Township 17, North, Range 18, East, Boise Meridian, and second point of diversion in the Northwest quarter of Northwest quarter of unsurveyed Section 2, Township 16, North, Range 18 East, Boise Meridian.

That Earl Millick is the owner of H. E. Survey No. 147, embracing a portion of, approximate, Sections twenty-nine, thirty-two and thirty-three in Township sixteen north of Range nineteen East of the Boise Meridian Idaho, more particularly bounded and described as follows: Beginning at corner No. 1 from which the North corner to sections four and five in Township fifteen North of Range nineteen east of the Boise Meridian, bears south twenty-two degrees eight minutes west twelve and forty-two hundredths chains distant; thence, north thirty-three degrees fifty-two minutes east ten and eighty-three hundredths chains to corner No. 2; thence north forty-five degrees thirty-seven minutes west twenty and seventy-three-hundredths chains to corner No. 3; thence, north thirty-seven degrees fifty-six minutes west twenty-four and sixty-seven-hundredths chains to corner No. 4; thence north fourteen degrees nineteen minutes west seventeen and eight-tenths chains to corner No. 5; thence north forty-three degrees twenty-five minutes west twenty-five and forty-six hundredths chains to corner No. 6; thence, south thirty-seven degrees fifty-four minutes west twenty and seventy-five-hundredths chains to corner No. 7; thence, south seventy-six degrees forty-six minutes east fifteen and sixty-eight-hundredths chains to corner No. 8; thence, south thirty-six degrees twenty minutes east seventy-two and eight-one-hundredths

#3091

TRANS. #3091

chains to corner No. 1, the place of beginning, containing eighty-six and three-hundredths acres. That he is entitled to 25 miners' inches or .5 cu. ft. per second of the waters of Morgan Creek from May 1st, 1906, and 25 miners' inches or .5 cu. ft. per second of the waters of Morgan Creek from May 1st, 1919, and 12½ miners' inches or .25 cu. ft. from Sept. 14, 1931, with point of diversion as follows: At a point in the Southeast quarter of the Southwest quarter of Section 29, Township 16, North, Range 19 East, Boise Meridian, and second point of diversion at a point in the Southeast quarter of the Southwest quarter of Section 29, Township 16, North, Range 19, East Boise Meridian.

That Inez W. Thomas is the owner of the Northeast quarter of the Southeast quarter, the South half of the Northeast quarter and the Southeast quarter of the Northwest quarter of Section 23 in Township 15, North, Range 19, East, in Custer County, Idaho. That she is entitled to 48 miners' inches or .96 cu. ft. per second of the waters of Morgan Creek from May 1st, 1902, and 12 miners' inches or .24 cu. ft. per second of the waters of Morgan Creek from September 14, 1931, with points of diversion in the Northwest quarter of the Northeast quarter of Section 23, Township 15, North, Range 19, East, Boise, Meridian, and second point of diversion in the Southwest quarter of Northeast quarter of Section 23, Township 15, North, Range 19, East Boise Meridian.

That Mike Hogan, defendant and cross-complainant is the owner of H. E. Survey No. 614, embracing a portion of approximately Sec. 6, Twp. 16 N. and Sec. 31 Twp. 17 N. all in R. 19 E. B. M., more particularly bounded and described as follows: Beginning at Cor. No. 1 from which U. S. Location Monument No. 70 bears N. 20 degrees 57' 13" E. 85.54 chains distant; thence S. 12 degrees 51' W. 50.13 chains to Cor. No. 2; thence S. 85 degrees 51' W. 4.26 chains to Cor. No. 3; thence N. 1 degree 39' W. 48.05 chains to corner No. 4; thence No. 68 degrees 31' E. 10 chains to Cor. No. 5; thence S. 71 degrees 29' E. 7.89 chains to Cor. No. 1, the place of beginning, containing 53 acres and 15 hundredths of an acre. That he is entitled to 40 miners' inches or .8 cu. ft. per second from May 1st, 1912, and 10 miners' inches or .2 cu. ft. per second of time to date from September 14, 1931, from Alder Creek a tributary of Morgan Creek, with point of diversion in the Northeast quarter of Northwest quarter unsurveyed Section 18, Township 17, North Range 19 E. B. M. Said water being diverted through a private ditch sometimes called the McKenney Ditch.

That Mike Hogan, defendant and cross-complainant is the owner of H. E. Survey No. 263, embracing a portion of, approximately Sec. 18, and 19 in Twp. 17 N. R. 19 E. B. M., Idaho, more particularly bounded and described as follows: Beginning at Cor. No. 1, from which the U. S. Location Monument No. 70 bears S. 7 degrees 42' E. 98.05 chains distant; thence N. 29 Deg. 20' W. 39.99 chains to Cor. No. 2; thence N. 35 degrees 48' W. 33.7 chains to Cor. No. 3; thence N. 9 degrees 26' W. 12.47 chains to Cor. No. 4; thence N. 80 degrees 40' E. 22.62 chains to Cor. No. 5; thence S. 19 degrees 10' E. 71.24 chains to Cor. No. 6; thence S. 22 degrees 26' W. 11.6 chains to Cor. No. 1, the place of beginning, containing 128.36 acres. That he is entitled to 35 miners' inches or .7 cu. ft. per second of time to date from May 1st, 1922, and 8.75 miners' inches or .14 cu. ft. per second of time to date from September 14, 1931, from the water of Van Horn Creek, a tributary of Morgan Creek, with point of diversion in the Southwest quarter of Southeast quarter of unsurveyed Section 31, Township 17, North, Range 19, East Boise Meridian, said water being diverted through a private ditch sometimes called the Cameron Ditch.

That Philip D. Beavers, defendant and cross-complainant is the owner of the Northeast quarter of Northwest quarter of Section 23, South half of Southwest quarter, Northwest quarter of Southwest quarter, Section 14, all in Township 15, North, Range 19 East Boise Meridian. That he is entitled to 40 miners' inches or .8 cu. ft. per second of time to date from May 1st, 1921, and 10 miners' inches or .2 cu. ft. per second of time to date from September 14, 1931, from the water of Morgan Creek, with point of diversion in the Northwest quarter of Southwest quarter of Section 14, Township 15, North, Range 19, East, Boise Meridian. Said water being diverted through a private ditch sometimes called the Beaver ditch.

That Paul Hacker, defendant and cross-complainant is the owner of the South half of Northeast quarter of Section 15, Township 15, North Range 19, East Boise Meridian. That he is entitled to 20 miners' inches or .4 cu. ft. per second of time to date from July 1st, 1921, and 5 miners' inches or .1 cu. ft. per second of time to date from September 14, 1931, from the water of Morgan Creek, with point of diversion in the Southwest quarter of Southeast quarter of unsurveyed Section 31, Township 17, North, Range 19, East Boise Meridian, said water being diverted through a private ditch sometimes called the Cameron Ditch.

JUL 30 1936

or .1 cu. ft. per second of time of the waters of Morgan Creek to date from September 14th, 1931, with point of diversion in the Northeast quarter of Northeast quarter of Section 15, Township 15, North, Range 19, East Boise Meridian. Said water being diverted through a private ditch sometimes called the Hacker Ditch.

That the Estate of George M. Turner, deceased, defendant and cross-complainant, is the owner of H. E. Survey, No. 70, embracing a portion of the unsurveyed Public Domain, Idaho, more particularly bounded and described as follows: Beginning at Cor. No. 1 from which U. S. Location Monument No. 70 bears N. 65 degrees 59' W. 3.62 chains distant; thence S. 15 degrees 10' W. 82.89 chains to Cor. No. 2; thence N. 72 degrees 38' W. 12.1 chains to Corner No. 3; thence N. 4 degrees 10' E. 34.39 chains to Cor. No. 4; thence N. 63 degrees 18' W. 9.3 chains to Corner No. 5; thence N. 15 degrees 8' E. 18.01 chains to Corner No. 6; thence N. 68 degrees 21' W. 15.18 chains to Corner No. 7; thence N. 20 degrees 2' E. 7.06 chains to Corner No. 8 thence S. 64 degrees 42' E. 30.16 chains to corner No. 9; thence N. 69 degrees E. 9.27 chains to Corner No. 1, the place of beginning, containing 153.55 acres. That said estate is entitled to 75 miners inches or 1.5 cu. ft. per second of time to date from May 1st, 1898; 35 miners inches or .7 cu. ft. per second of time to date from May 1st, 1916; 25 miners inches or .5 cu. ft. per second of time to date from May 1st, 1920, and 35 miners inches or .7 cu. ft. per second of time to date from September 14th, 1931, all from the waters of Morgan Creek. One point of diversion being 5,804 ft. North and 321 ft. East of said corner 2-70 and the other point of diversion being 10,368 ft. North and 2,153 ft. East of said corner No. 2-70, all of said water being diverted through private ditches. Morgan Creek includes its tributaries.

VII. That each and every person hereinbefore decreed water shall at their own cost and expense install (if not already installed) and maintain proper lock headgates and measuring devices at their respective points of diversion, and there shall be no water delivered until the same are installed and kept in good condition as required by the watermaster of said stream.

VIII. It is further Adjudged and decreed that each of the parties to this action shall pay his or her own costs of this action.

IX. That each and every of the parties to this suit plaintiffs and defendant, their agents, servants, attorneys and employees, and each, every and all persons acting in aid of and for any of the parties to this suit are hereby forever restrained and enjoined from in any way or manner interfering with or diverting or using the waters of said stream except in accordance with the terms and provisions of this decree.

Dated this 2nd day of May, 1935.

STATE OF IDAHO, }
COUNTY OF CUSTER. } ss.

JUL 30 1936

I, Emmett Donahue, Ex-Officio Recorder in and for the County of Custer, in the State of Idaho, do hereby certify that I have compared the foregoing copy with the record which appears in Volume 4 of Judgments, at Pages 14-18 of the Records of Custer County, Idaho, and the same is a full, true and complete copy of such record.

IN WITNESS WHEREOF I have hereunto set my hand and affixed my Seal this

6 day of May, 1935

Emmett Donahue

Ex-Officio Recorder

By John Boyd, sept.